

Precision Piezo Stage | PPS-60

The PPS-60 is high-precision, long travel linear stage. The same stage is available with piezo motor, linear motor or stepper motor drive. Ball bearings assure high stiffness and guiding accuracy for loads up to 150 N. The PPS-60 is available with an optional linear encoder for increased resolution and repeatability. PPS-60 stages can be mounted in XY without any adapter, and a Z-axis can be added with the use of a standard mounting bracket.

KEY FEATURES

- Travel ranges up to 300 mm (longer travel available on request)
- 2 nm closed loop encoder resolution
- Load capacity up to 15 kg
- Integrated mechanical limit switches
- Vacuum versions are available

TECHNICAL DATA

Travel range [mm]	25	50	100	200	300
Straightness / Flatness [μm]	± 2.5	± 4	± 6	± 8	± 10
Pitch [μrad]	± 50	± 75	± 100	± 125	± 150
Yaw [μrad]	± 50	± 75	± 100	± 125	± 150
Weight [g], Open Loop	335	380	480	660	850
Weight [g], Closed Loop	345	390	490	670	860
Motor option	Piezo Motor				
Speed, max [mm/s]	2 (MMC-100), 5 (MMC-110)				
Encoder option	Open Loop	Analog (1 V_{pp})	Digital (RS-422)		
Resolution, typical [nm]	1	10	2		
Repeatability, bi-directional [nm]	n/a	± 500	± 100		
Repeatability, uni-directional [nm]	n/a	500	100		
Materials	aluminum body, steel bearing (other materials i.e. stainless steel, titanium, etc. available upon request)				

ORDERING INFORMATION[†]

PPS-60- 1

DRIVE	Piezo Motor, PM-003	1
TRAVEL	25 mm	1
	50 mm	2
	100 mm	3
	200 mm	4
	300 mm	5
ENCODER	None	0
	Analog (1 V _{pp})	2
	Digital (RS-422)	3
LIMIT SWITCH	None	0
	Mechanical [†]	1
ENVIRONMENT	Atmospheric	0
	High Vacuum, 10 ⁻⁶ mbar	6
	Ultra High Vacuum, 10 ⁻⁹ mbar	9

[†] not needed with encoder

[‡] refer to product manual for additional information.

Load, max	F _x [N]	F _y [N]	F _z [N]	M _x [N·m]	M _y [N·m]	M _z [N·m]	k _{ax} [$\mu\text{rad/N·m}$]	k _{ay} [$\mu\text{rad/N·m}$]
PM-003	5	100	150	10	10	10	100	100

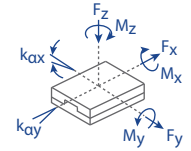
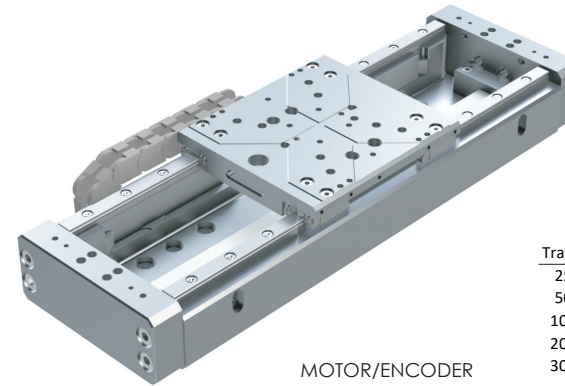

Travel	L	A	B	C
25	117	75	25	50.8
50	142	75	25	50.8
100	192	125	75	101.6
200	292	225	175	203.2
300	392	325	275	304.8

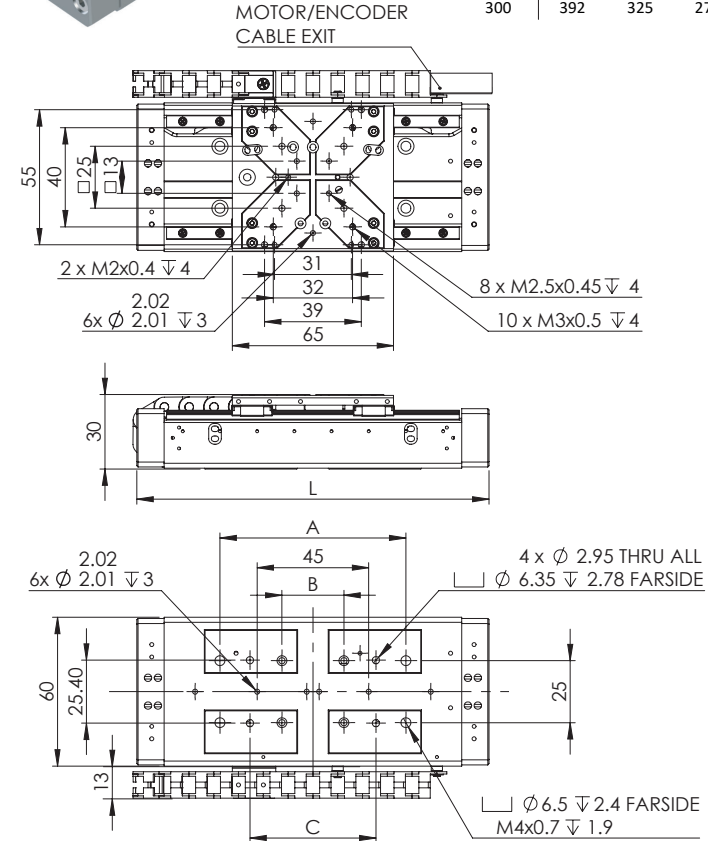

Specifications are subject to change without notice.

* 50 mm travel version shown

* All dimensions are in millimeters