

6 Degree of Freedom Platform | X-BOT-120

NEW

www.micronixusa.com | info@micronixusa.com | phone: +1 (949) 480 0538 | fax: +1 (949) 480 0538

X-BOT-120 is a miniature “hexapod” with 70mm height for positioning and adjustment of precision components in 6 degrees of freedom with nm resolution. Using an innovative, proprietary arrangement of 6 nanopositioners, the X-Bot-120 achieves large motion ranges in an extremely compact form factor. An absolute encoder feedback option eliminates homing on power-up. An optional rotation stage (PR-32L) for 360° z-rotation can be integrated under the carrier platform. HV and UHV as well as non-magnetic versions are available. Custom travel ranges upon request.

KEY FEATURES

- Travel range of $\pm 6 \times \pm 6 \times +3.5/-6$ xyz, $\pm 7^\circ \times \pm 9^\circ \times \pm 6^\circ$ from center position
- Load capacity up to 500g
- Open Aperture 33mm diameter
- Crossed roller bearings
- 70 mm height at center position
- Vacuum and non-magnetic versions available

TECHNICAL DATA

<i>T_x, T_y Travel range [mm]</i>	± 6
<i>T_z Travel range [mm]</i>	+3.5/-6
<i>R_x Travel range [deg]</i>	+7/-9
<i>R_y Travel range [deg]</i>	± 9
<i>R_z Travel range [deg]</i>	± 6
Motor option	Piezo Motor
<i>Speed, max</i>	5mm/s, 3 deg/s (MMC-110)
Encoder option	Absolute
<i>Resolution T_x, T_y, T_z [nm]</i>	12.5
<i>Resolution R_x, R_y, R_z [μdeg]</i>	50
<i>Repeatability T_x, T_y, T_z [nm]</i>	50
<i>Repeatability R_x, R_y, R_z [μdeg]</i>	50
<i>Materials</i>	aluminum body, steel bearing (other materials i.e. stainless steel, titanium, etc. available upon request)

ORDERING INFORMATION

X-BOT-120- 1 1 5 0

DRIVE	Piezo Motor, PM-002.....	1
TRAVEL	See Technical Data.....	1
ENCODER	Absolute (BiSS C)	5
LIMIT SWITCH	None	0
ENVIRONMENT	Atmospheric	0
	High Vacuum, 10 ⁻⁶ mbar	6
	Ultra High Vacuum, 10 ⁻⁹ mbar	9
	Non-Magnetic	M

Load, max	F _x [N]	F _y [N]	F _z [N]	M _x [N-m]	M _y [N-m]	M _z [N-m]	k _{ax} [μ rad/N-m]	k _{ay} [μ rad/N-m]
PM-002	2	2	5	-	-	-	-	-

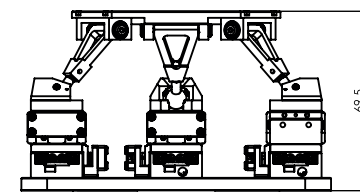
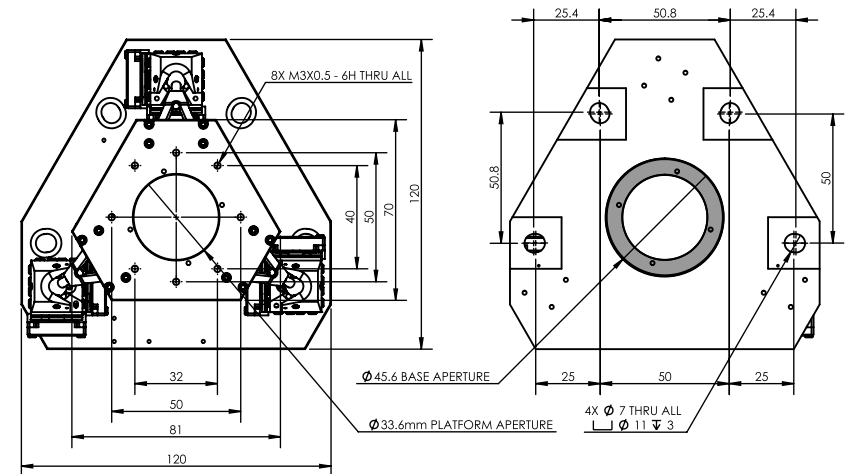
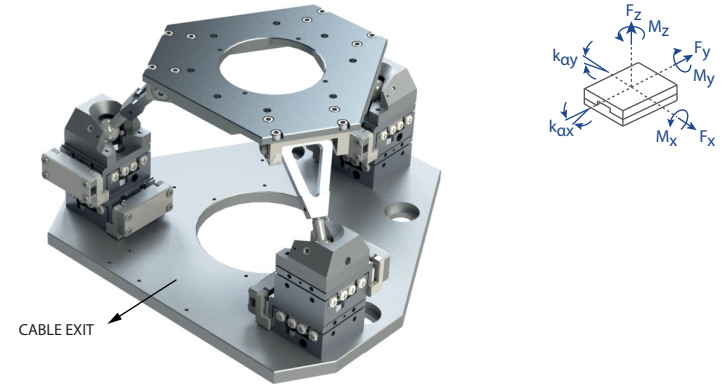

Specifications are subject to change without notice.