

Elevation Stage | PZS-90

The PZS-90 elevation stage is designed for applications with limited space conditions. Pre-loaded crossed roller bearings assure smooth motion and high stiffness. The PZS-90 allows for a highly rigid XZ or XYZ setup without the need for adapter brackets when combined with the VT-50L series & PPS-60 series of linear stages. The PZS-90 stage is driven by a 2-phase stepper motor and is equipped with two mechanical limit switches. An optional linear encoder provides higher accuracy versus the open loop option. Versions capable of operation in vacuum (10^{-6} mbar) are available. The PZS-90 is compatible with the MMC-200 controller.

KEY FEATURES

- Travel range of 35 mm
- 50 nm closed loop encoder resolution
- Load capacity up to 15 kg
- Steel crossed roller bearing
- Integrated mechanical limit switches
- Vacuum versions available

TECHNICAL DATA

Travel range [mm]	35		
Straightness / Flatness [μm]	± 3		
Pitch [μrad]	± 200		
Yaw [μrad]	± 200		
Weight [g], Open Loop	925		
Weight [g], Closed Loop	950		
Motor option	2-Phase Stepper Motor		
Speed, max [mm/s]	10		
Encoder option	None (open loop)	Analog (1 V _{pp})	Digital (RS-422)
Resolution, typical [μm]	0.5	0.05	0.05
Repeatability, bi-directional [μm]	± 2	± 0.1	± 0.1
Repeatability, uni-directional [μm]	0.5	0.1	0.1
Materials	aluminum body, steel bearing (other materials i.e. stainless steel, titanium, etc. available upon request)		

ORDERING INFORMATION

PZS-90- 1 1 1

DRIVE	Stepper Motor, SM-003	1
TRAVEL	35 mm	1
ENCODER	None	0
	Analog (1 V _{pp})	2
	Digital (RS-422)	3
LIMIT SWITCH	Mechanical	1
	Atmospheric	0
ENVIRONMENT	High Vacuum, 10^{-6} mbar	6

Load, max	F _x [N]	F _y [N]	F _z [N]	M _x [N-m]	M _y [N-m]	M _z [N-m]	k _{ax} [$\mu\text{rad}/\text{N-m}$]	k _{ay} [$\mu\text{rad}/\text{N-m}$]
SM-003	75	75	150	50	50	100	50	50

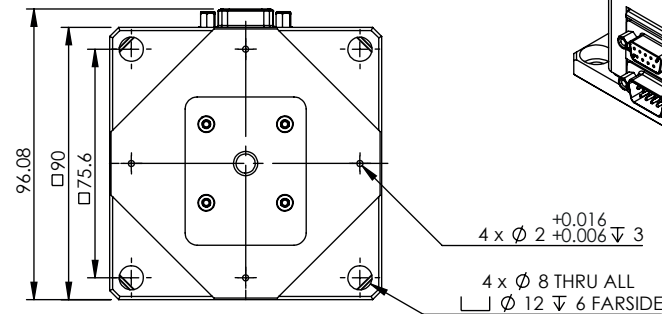
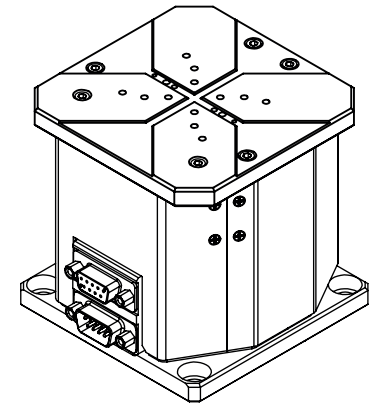
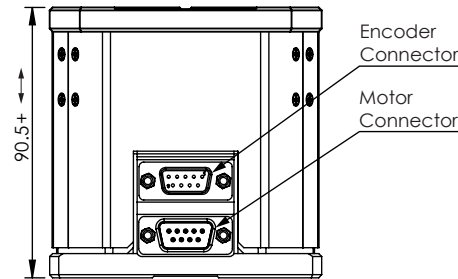
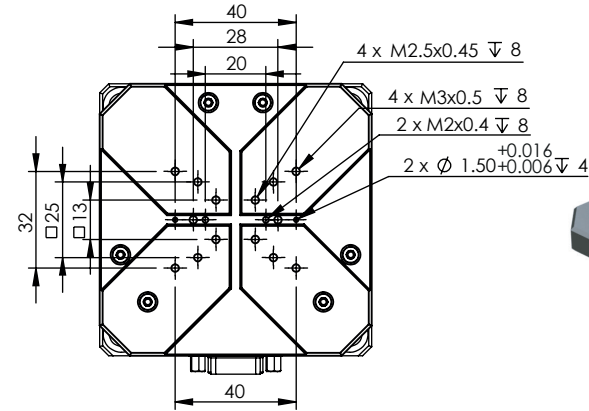
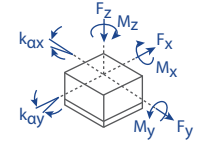

Specifications are subject to change without notice.